

Hyper Multi TOPLED®
Hyper-Bright LED
Lead (Pb) Free Product - RoHS Compliant

LSG T676



Besondere Merkmale

- **Gehäusertyp:** weißes P-LCC-4 Gehäuse, farbloser klarer Verguss
- **Besonderheit des Bauteils:** beide Leuchtdiodenchips getrennt ansteuerbar, hohe Signalwirkung durch Farbwechsel der LED möglich
- **Wellenlänge:** 633 nm (super-rot), 570 nm (grün)
- **Abstrahlwinkel:** Lambertscher Strahler (120°)
- **Technologie:** InGaAlP
- **optischer Wirkungsgrad:** 7 lm/W (super-rot), 5 lm/W grün
- **Gruppierungsparameter:** Lichtstärke, Wellenlänge
- **Verarbeitungsmethode:** für alle SMT-Bestücktechniken geeignet
- **Lötmethode:** IR Reflow Löten und Wellenlöten (TTW)
- **Vorbehandlung:** nach JEDEC Level 2
- **Gurtung:** 8-mm Gurt mit 2000/Rolle, ø180 mm oder 8000/Rolle, ø330 mm
- **Erweiterte Korrosionsfestigkeit:** Details siehe Seite 9

Anwendungen

- optischer Indikator
- Einkopplung in Lichtleiter
- Hinterleuchtung (LCD, Schalter, Tasten, Displays, Werbebeleuchtung, Allgemeinbeleuchtung)

Features

- **package:** white P-LCC-4 package, colorless clear resin
- **feature of the device:** both chips can be controlled separately, high signal efficiency possible by color change of the LED
- **wavelength:** 633 nm (super-red), 570 nm (green)
- **viewing angle:** Lambertian Emitter (120°)
- **technology:** InGaAlP
- **optical efficiency:** 7 lm/W (super-red), 5 lm/W (green)
- **grouping parameter:** luminous intensity, wavelength
- **assembly methods:** suitable for all SMT assembly methods
- **soldering methods:** IR reflow soldering and TTW soldering
- **preconditioning:** acc. to JEDEC Level 2
- **taping:** 8 mm tape with 2000/reel, ø180 mm or 8000/reel, ø330 mm
- **Superior Corrosion Robustness:** details see page 9

Applications

- optical indicators
- coupling into light guides
- backlighting (LCD, switches, keys, displays, illuminated advertising, general lighting)

Bestellinformation
Ordering Information

Typ Type	Emissionsfarbe Color of Emission	Lichtstärke ^{1) Seite 16} Luminous Intensity ^{1) page 16} $I_F = 20 \text{ mA}$ $I_V \text{ (mcd)}$		Bestellnummer Ordering Code
		color 1	color 2	
		LSG T676- P7Q7-1+N7P7-24	super-red / green	

Anm.: Die oben genannten Typbezeichnungen umfassen die bestellbaren Selektionen. Diese bestehen aus wenigen Helligkeitsgruppen (siehe **Seite 5** für nähere Informationen). Es wird nur eine einzige Helligkeitsgruppe pro Gurt und Farbe geliefert. Z.B.: LSG T676-**P7Q7-1+N7P7-24** bedeutet, dass auf dem Gurt nur eine der Helligkeitsgruppen P7, P9, Q, Q5 oder Q7 für super-red enthalten ist.

Um die Liefersicherheit zu gewährleisten, können einzelne Helligkeitsgruppen nicht bestellt werden.

Gleiches gilt für die Farben, bei denen Wellenlängengruppen gemessen und gruppiert werden. Pro Gurt wird nur eine Wellenlängengruppe geliefert. Z.B.: LSG T676-P7Q7-1+N7P7-24 bedeutet, dass auf dem Gurt nur eine der Wellenlängengruppen -2, -3, oder -4 enthalten ist (siehe **Seite 5** für nähere Information). LSG T676-P7Q7-1+N7P7-24 bedeutet, dass das Bauteil innerhalb der auf **Seite 4** spezifizierten Grenzen geliefert wird.

Um die Liefersicherheit zu gewährleisten, können einzelne Wellenlängengruppen nicht bestellt werden.

Note: The above Type Numbers represent the order groups which include only a few brightness groups (see **page 5** for explanation). Only one group per color will be shipped on each reel (there will be no mixing of two groups per color on each reel). E.g. LSG T676-**P7Q7-1+N2Q2-1** means that only one group P7, P9, Q, Q5 or Q7 for super-red will be shippable for any one reel and color.

In order to ensure availability, single brightness groups will not be orderable.

In a similar manner for colors where wavelength groups are measured and binned, single wavelength groups will be shipped on any one reel. E.g. LSG T676-P7Q7-1+N7P7-24 means that only 1 wavelength group -2, -3 or -4 will be shippable. LSG T676-P7Q7-1+N7P7-24 means that the device will be shipped within the specified limits as stated on **page 4**.

In order to ensure availability, single wavelength groups will not be orderable (see **page 5** for explanation).

Grenzwerte
Maximum Ratings

Bezeichnung Parameter	Symbol Symbol	Werte Values		Einheit Unit
		super red	green	
Betriebstemperatur Operating temperature range	T_{op}	- 40 ... + 100		°C
Lagertemperatur Storage temperature range	T_{stg}	- 40 ... + 100		°C
Sperrschichttemperatur Junction temperature	T_j	+ 125		°C
Durchlassstrom Forward current ($T_A=25^\circ\text{C}$)	I_F	30		mA
Stoßstrom Surge current $t \leq 10 \mu\text{s}$, $D = 0.005$, $T_A=25^\circ\text{C}$	I_{FM}	1	0.5	A
Sperrspannung ^{3) Seite 16} Reverse voltage ^{3) page 16} ($T_A=25^\circ\text{C}$)	V_R	12		V
Leistungsaufnahme Power consumption ($T_A=25^\circ\text{C}$)	P_{tot}	80		mW
Wärmewiderstand Thermal resistance				
Sperrschicht/Umgebung ^{4) Seite 16} Junction/air ^{4) page 16}	1 chip on $R_{th JA}$	580		K/W
	2 chips on $R_{th JA}$	790		K/W
Sperrschicht/Löt看pad Junction/solder point	1 chip on $R_{th JS}$	340		K/W
	2 chips on $R_{th JS}$	470		K/W

Kennwerte
Characteristics
 $(T_A = 25\text{ °C})$

Bezeichnung Parameter	Symbol Symbol	Werte Values		Einheit Unit
		super red	green	
Wellenlänge des emittierten Lichtes (typ.) Wavelength at peak emission $I_F = 20\text{ mA}$	λ_{peak}	645	572	nm
Dominantwellenlänge ⁵⁾ Seite 16 Dominant wavelength ⁵⁾ page 16 $I_F = 20\text{ mA}$	λ_{dom}	633 ± 6	570* -4/+5	nm
Spektrale Bandbreite bei 50 % $I_{\text{rel max}}$ (typ.) Spectral bandwidth at 50 % $I_{\text{rel max}}$ $I_F = 20\text{ mA}$	$\Delta\lambda$	16	22	nm
Abstrahlwinkel bei 50 % I_V (Vollwinkel) (typ.) Viewing angle at 50 % I_V	2φ	120	120	Grad deg.
Durchlassspannung ⁶⁾ Seite 16 Forward voltage ⁶⁾ page 16 $I_F = 20\text{ mA}$	(min.) V_F (typ.) V_F (max.) V_F	1.8 2.0 2.3	1.8 2.0 2.4	V V V
Sperrstrom (typ.) Reverse current (max.) $V_R = 12\text{ V}$	I_R I_R	0.01 10	0.01 10	μA μA
Temperaturkoeffizient von λ_{peak} (typ.) Temperature coefficient of λ_{peak} $I_F = 20\text{ mA}; -10\text{ °C} \leq T \leq 100\text{ °C}$	$TC_{\lambda_{\text{peak}}}$	0.14	0.12	nm/K
Temperaturkoeffizient von λ_{dom} (typ.) Temperature coefficient of λ_{dom} $I_F = 20\text{ mA}; -10\text{ °C} \leq T \leq 100\text{ °C}$	$TC_{\lambda_{\text{dom}}}$	0.05	0.10	nm/K
Temperaturkoeffizient von V_F (typ.) Temperature coefficient of V_F $I_F = 20\text{ mA}; -10\text{ °C} \leq T \leq 100\text{ °C}$	TC_V	- 2.0	- 2.6	mV/K
Optischer Wirkungsgrad (typ.) Optical efficiency $I_F = 20\text{ mA}$	η_{opt}	7	5	lm/W

* Einzelgruppen siehe Seite 5
Individual groups on page 5

Floating Bins

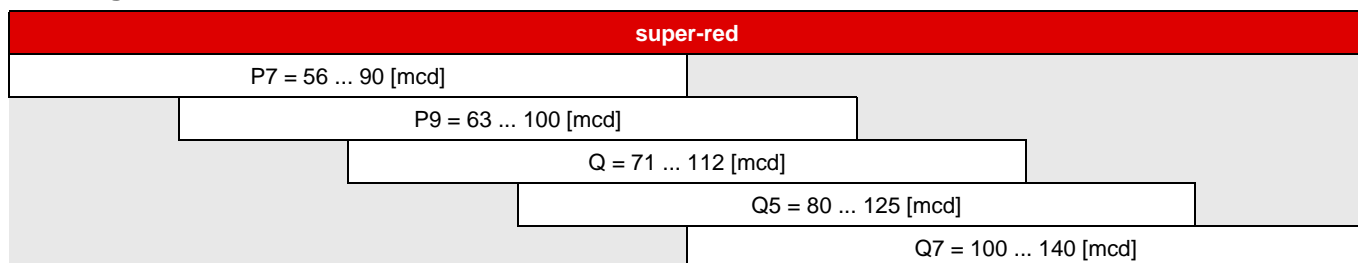

Floating Bins

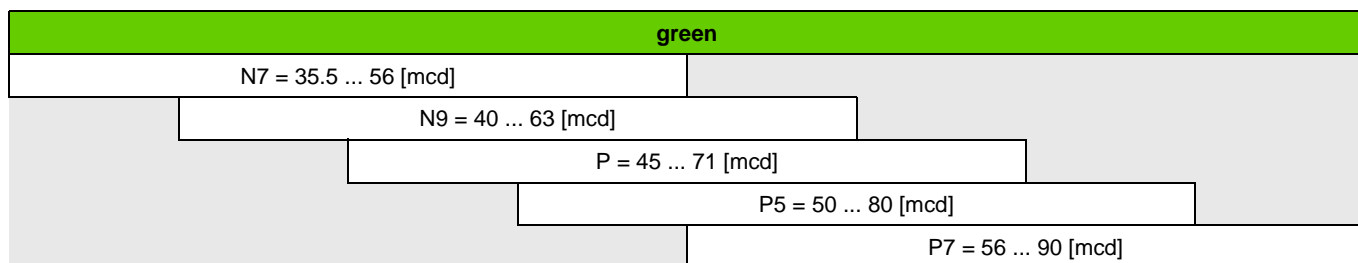

Wellenlängengruppen (Dominantwellenlänge)⁵⁾ Seite 16

Wavelength Groups (Dominant Wavelength)⁵⁾ page 16

Gruppe Group	green		Einheit Unit
	min.	max.	
2	566	569	nm
3	569	572	nm
4	572	575	nm

Gruppenbezeichnung auf Etikett

Group Name on Label

Beispiel: Q5-1 + P5-4

Example: Q5-1 + P5-4

Helligkeitsgruppe	Wellenlänge (keine Gruppierung)	Helligkeitsgruppe	Wellenlänge
Brightness Group	Wavelength (no grouping)	Brightness Group	Wavelength
(super red)	(super-red)	(green)	(green)
Q5	1	P5	4

Anm.: In einer Verpackungseinheit / Gurt ist immer nur eine Helligkeitsgruppe pro Farbe enthalten.

Note: No packing unit / tape ever contains more than one brightness group for each color.

Relative spektrale Emission^{2) Seite 16}

Relative Spectral Emission^{2) page 16}

$V(\lambda)$ = spektrale Augenempfindlichkeit / Standard eye response curve

$I_{rel} = f(\lambda); T_A = 25\text{ °C}; I_F = 20\text{ mA}$

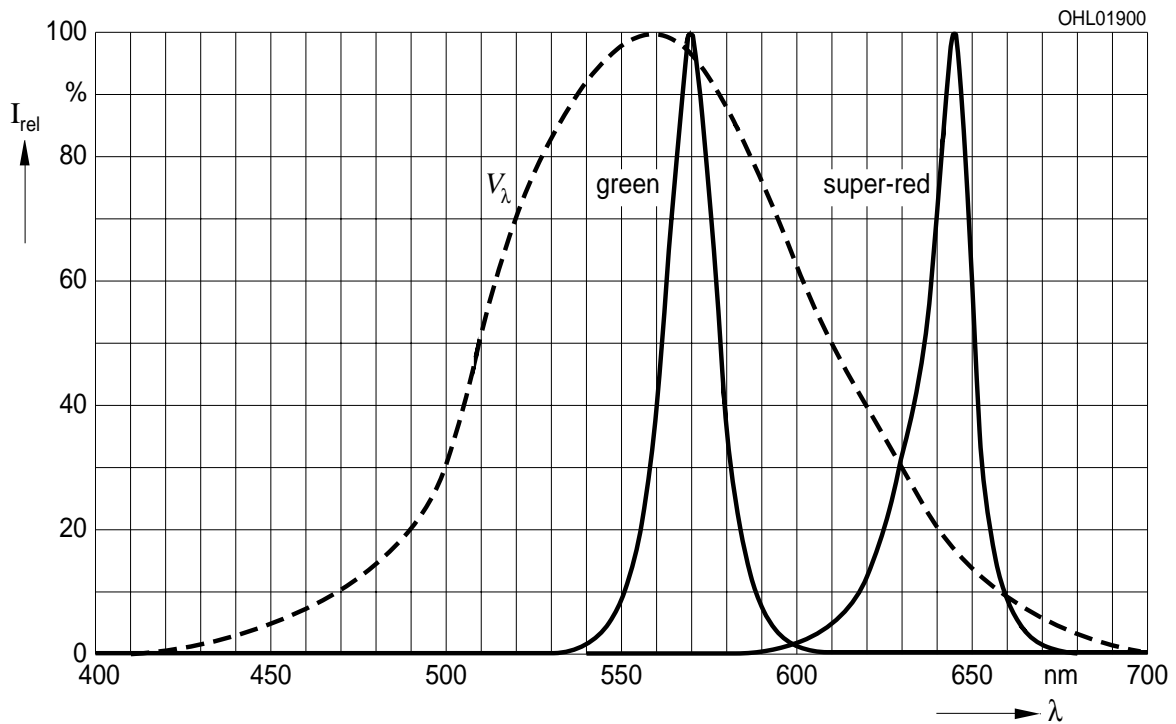

Abstrahlcharakteristik^{2) Seite 16}

Radiation Characteristic^{2) page 16}

$I_{rel} = f(\varphi); T_A = 25\text{ °C}$

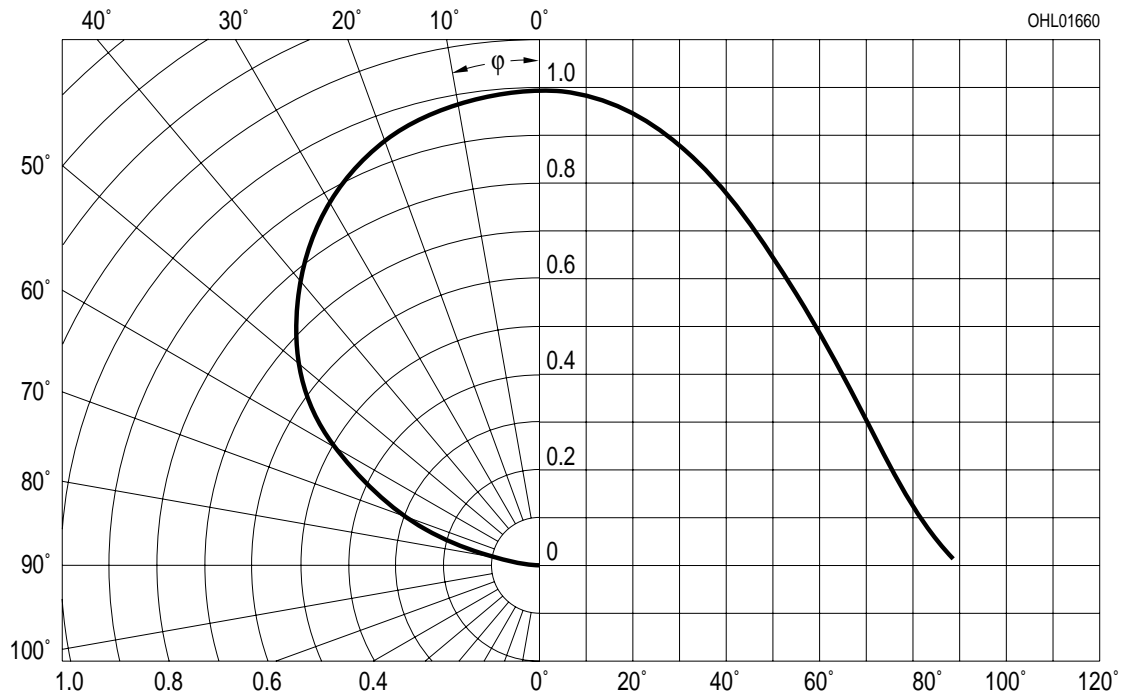

Durchlassstrom^{2) Seite 16}

Forward Current^{2) page 16}

$I_F = f(V_F); T_A = 25\text{ °C}$

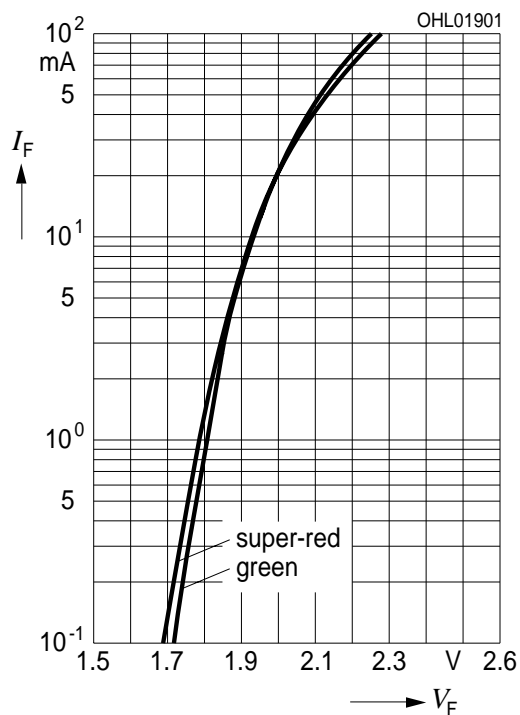

Relative Lichtstärke^{2) 7) Seite 16}

Relative Luminous Intensity^{2) 7) page 16}

$I_V/I_{V(20\text{ mA})} = f(I_F); T_A = 25\text{ °C}$

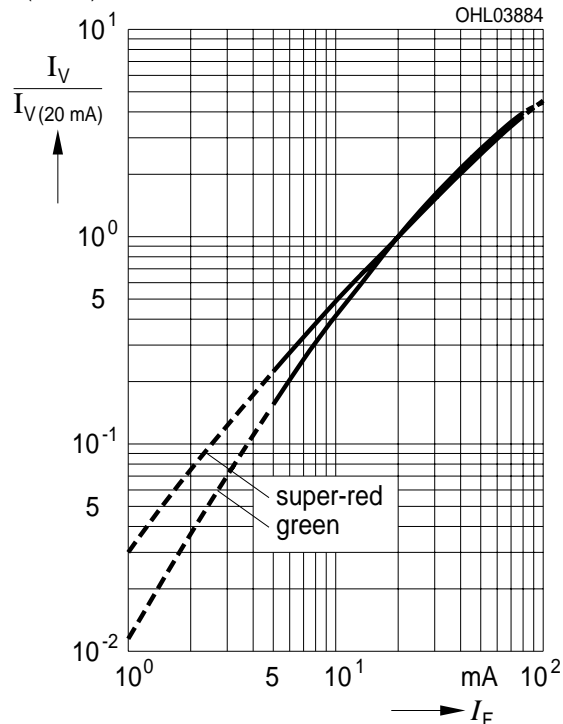

Relative Lichtstärke^{2) Seite 16}

Relative Luminous Intensity^{2) page 16}

$I_V/I_{V(25\text{ °C})} = f(T_j); I_F = 20\text{ mA}$

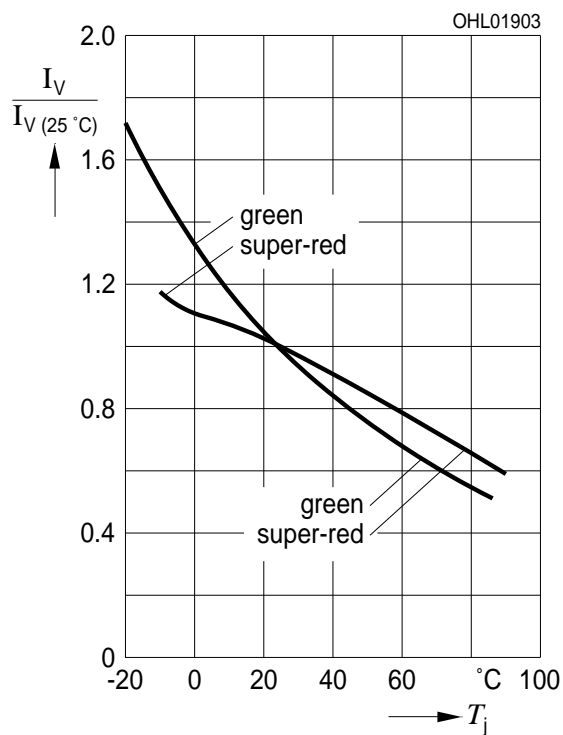

Maximal zulässiger Durchlassstrom
Max. Permissible Forward Current

$I_F = f(T)$

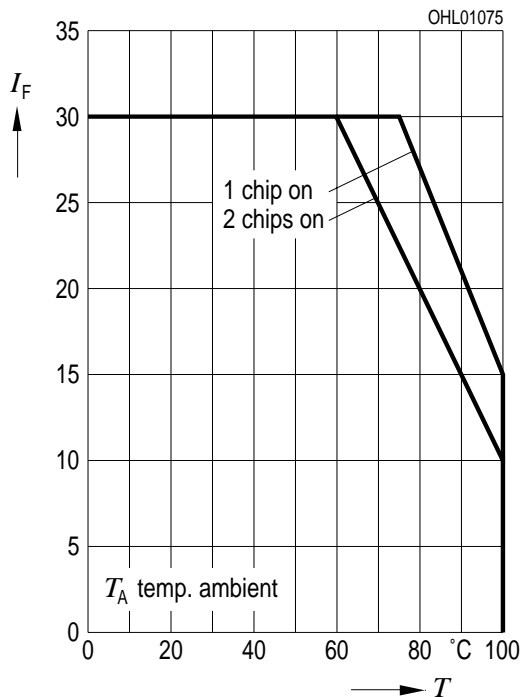

Maximal zulässiger Durchlassstrom
Max. Permissible Forward Current

$I_F = f(T)$

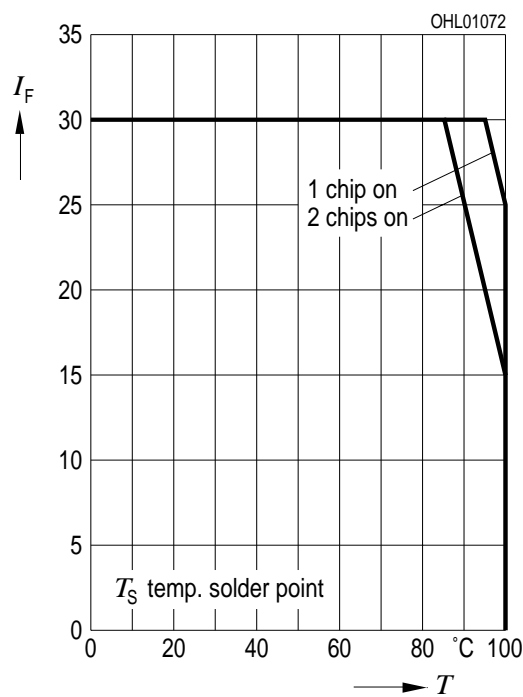

Zulässige Impulsbelastbarkeit $I_F = f(t_p)$
Permissible Pulse Handling Capability

Duty cycle $D =$ parameter, $T_A = 25\text{ °C}$

super red

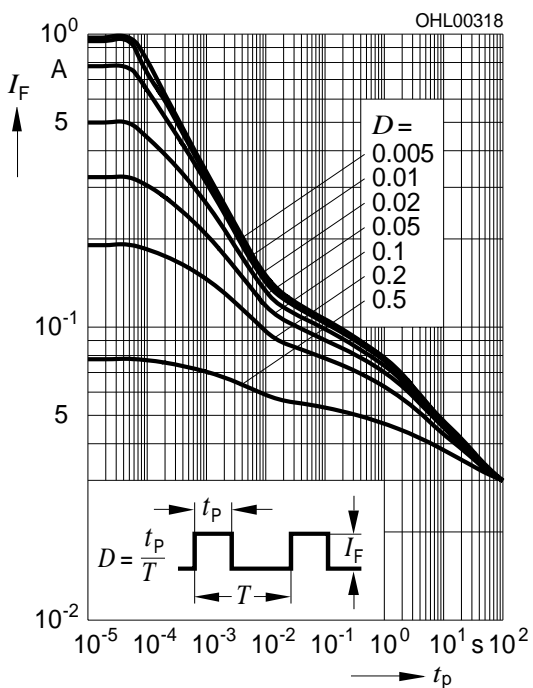

Maßzeichnung⁸⁾ Seite 16
 Package Outlines⁸⁾ page 16

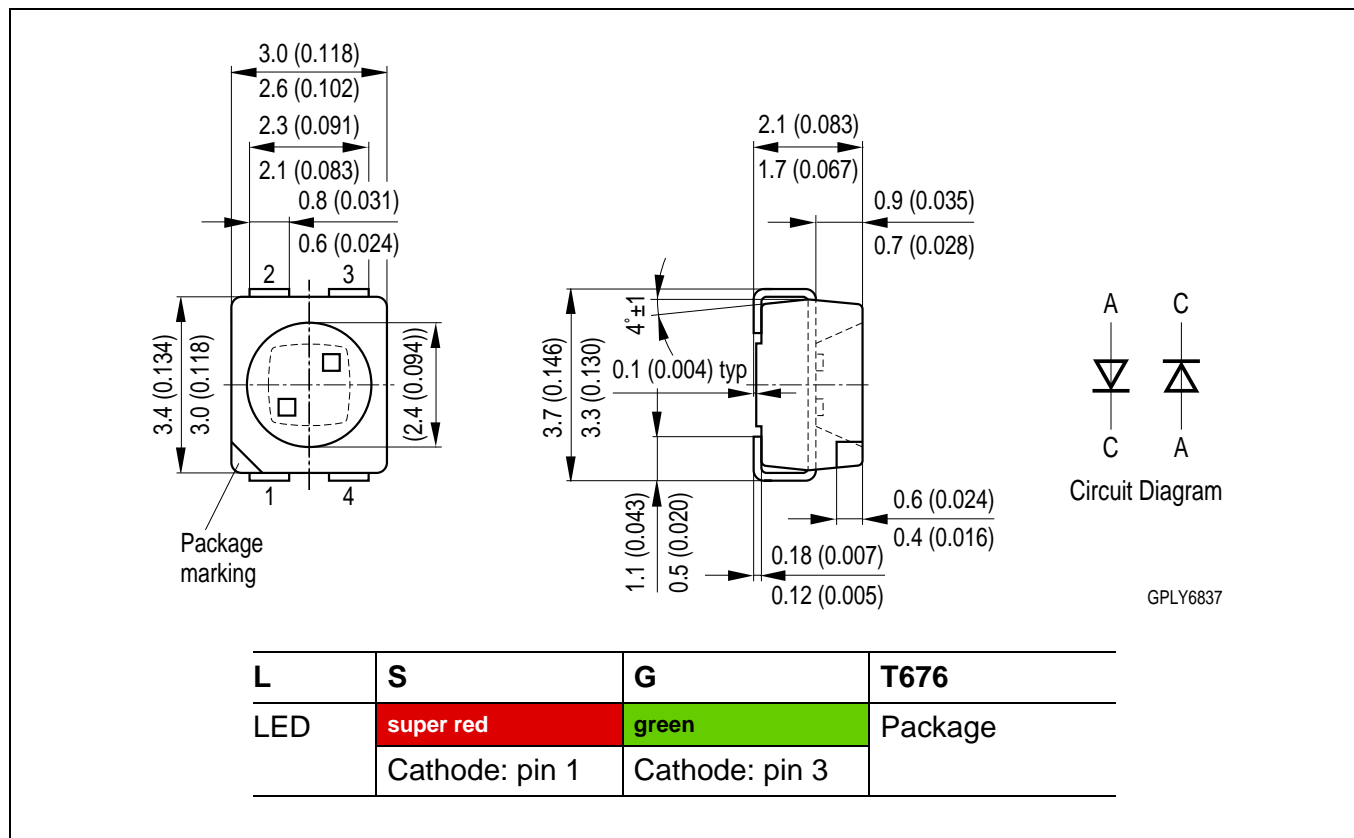

Korrosionsfestigkeit besser als EN 60068-2-60 (method 4):
 mit erweitertem Korrosionstest: 40°C / 90%rh / 15ppm H₂S / 336h

Corrosion robustness better than EN 60068-2-60 (method 4):
 with enhanced corrosion test: 40°C / 90%rh / 15ppm H₂S / 336h

Gewicht / Approx. weight: 35 mg

Gurtung / Polarität und Lage⁸⁾ Seite 16

Verpackungseinheit 2000/Rolle, ø180 mm
oder 8000/Rolle, ø330 mm

Method of Taping / Polarity and Orientation⁸⁾ page 16

Packing unit 2000/reel, ø180 mm
or 8000/reel, ø330 mm

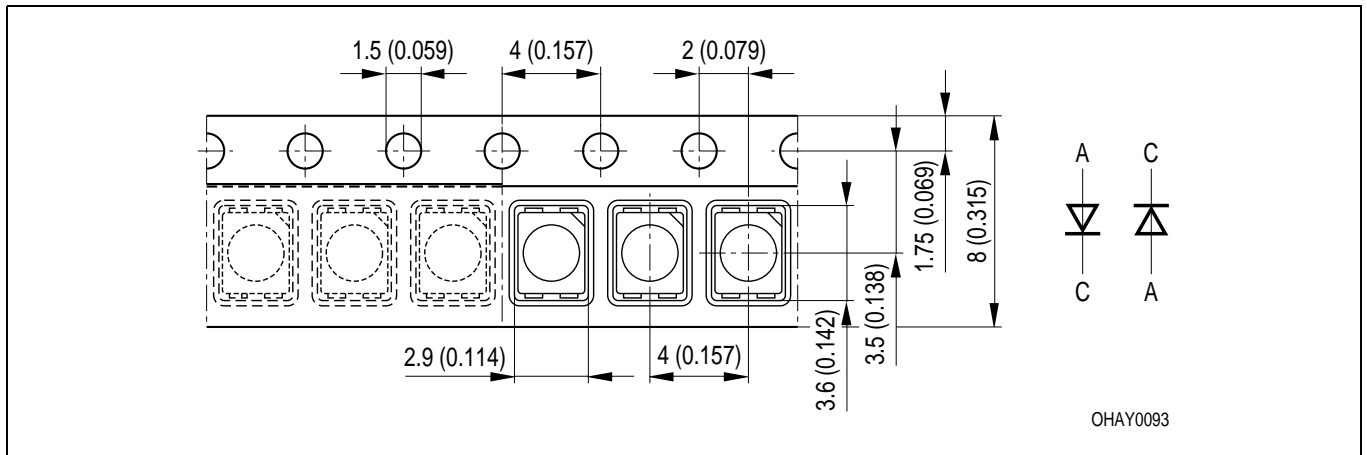

Empfohlenes Lötpad Design^{8) Seite 16}
Recommended Solder Pad^{8) page 16}

IR Reflow Löten
IR Reflow Soldering

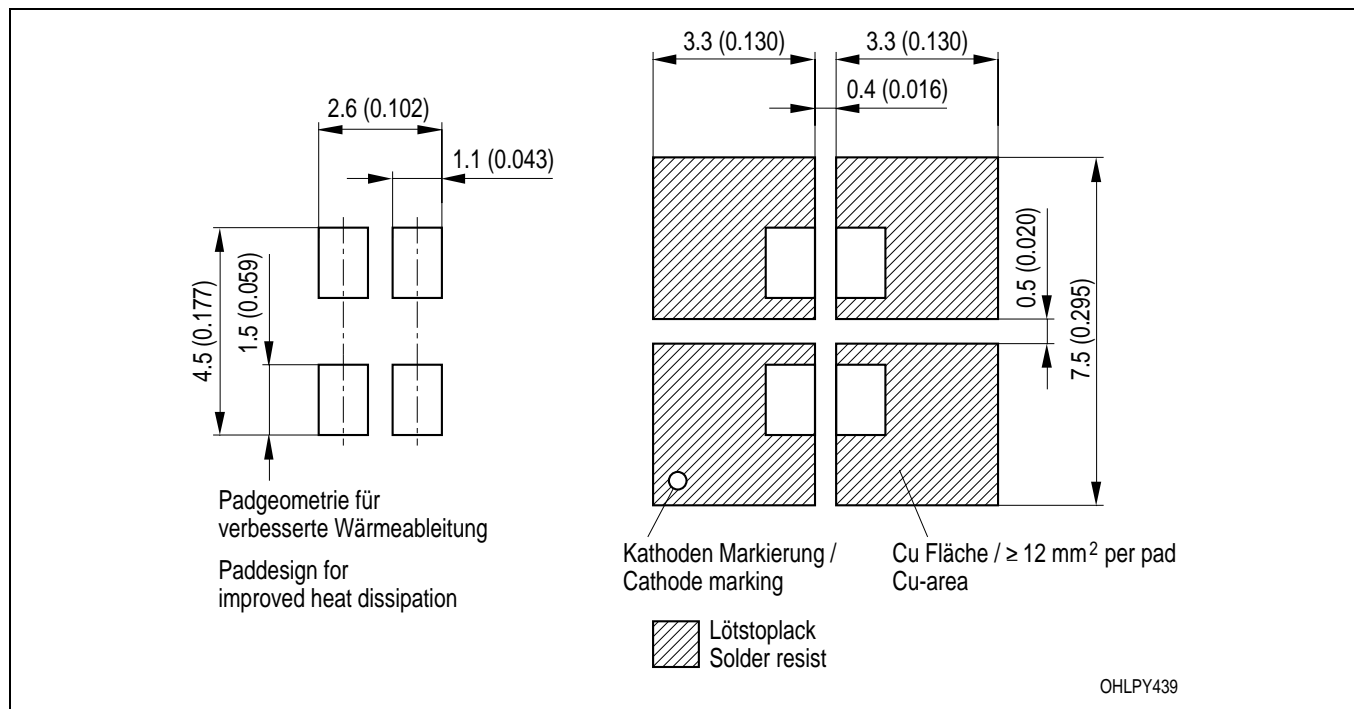

Empfohlenes Lötpad Design^{8) Seite 16}
Recommended Solder Pad^{8) page 16}

Wellenlöten (TTW)
TTW Soldering

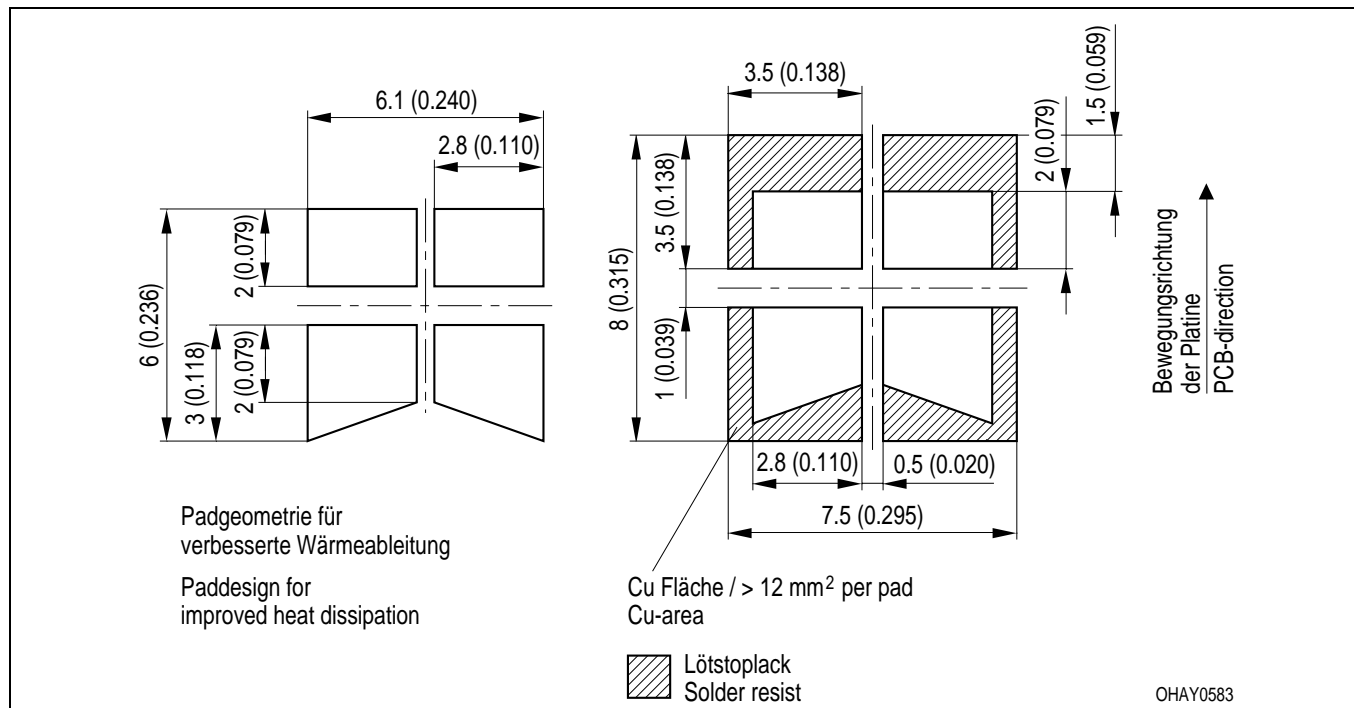

Lötbedingungen
Soldering Conditions

Vorbehandlung nach JEDEC Level 2
Preconditioning acc. to JEDEC Level 2

IR-Reflow Lötprofil für bleifreies Löt
IR Reflow Soldering Profile for lead free soldering

(nach J-STD-020B)
(acc. to J-STD-020B)

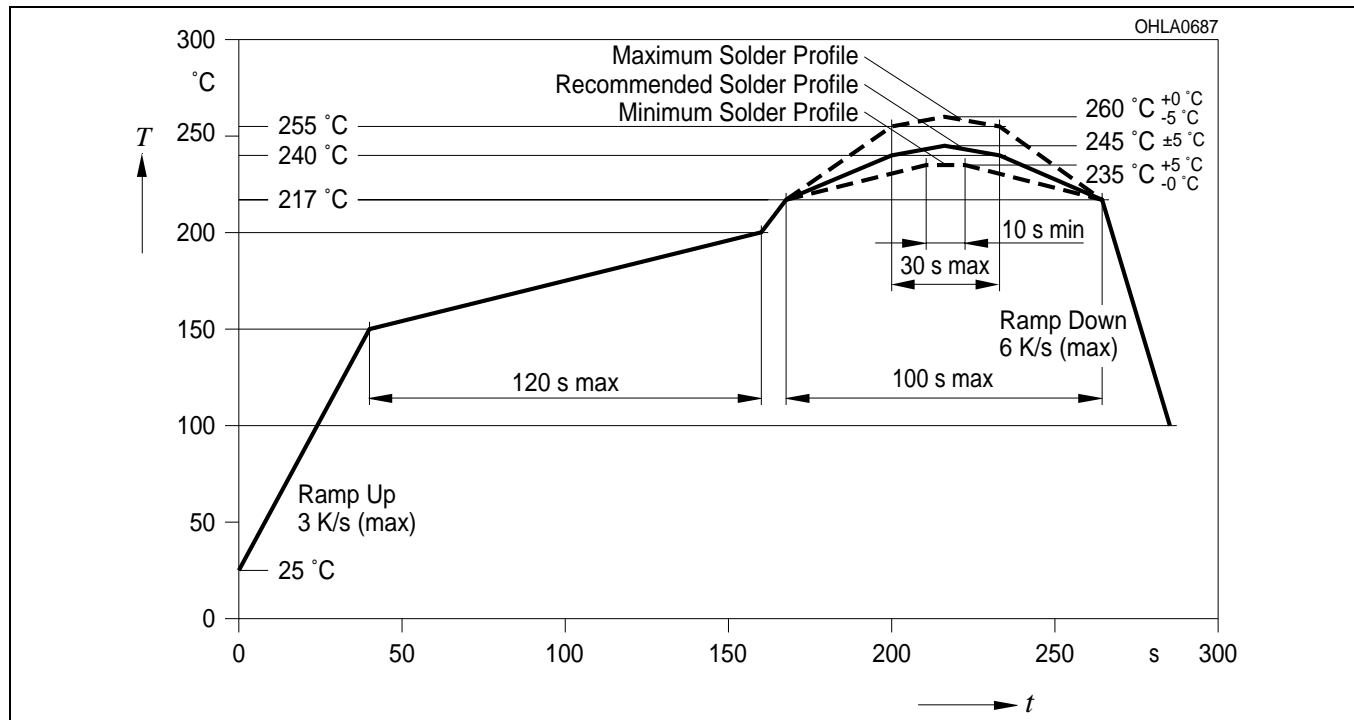

Wellenlöt (TTW)
TTW Soldering

(nach CECC 00802)
(acc. to CECC 00802)

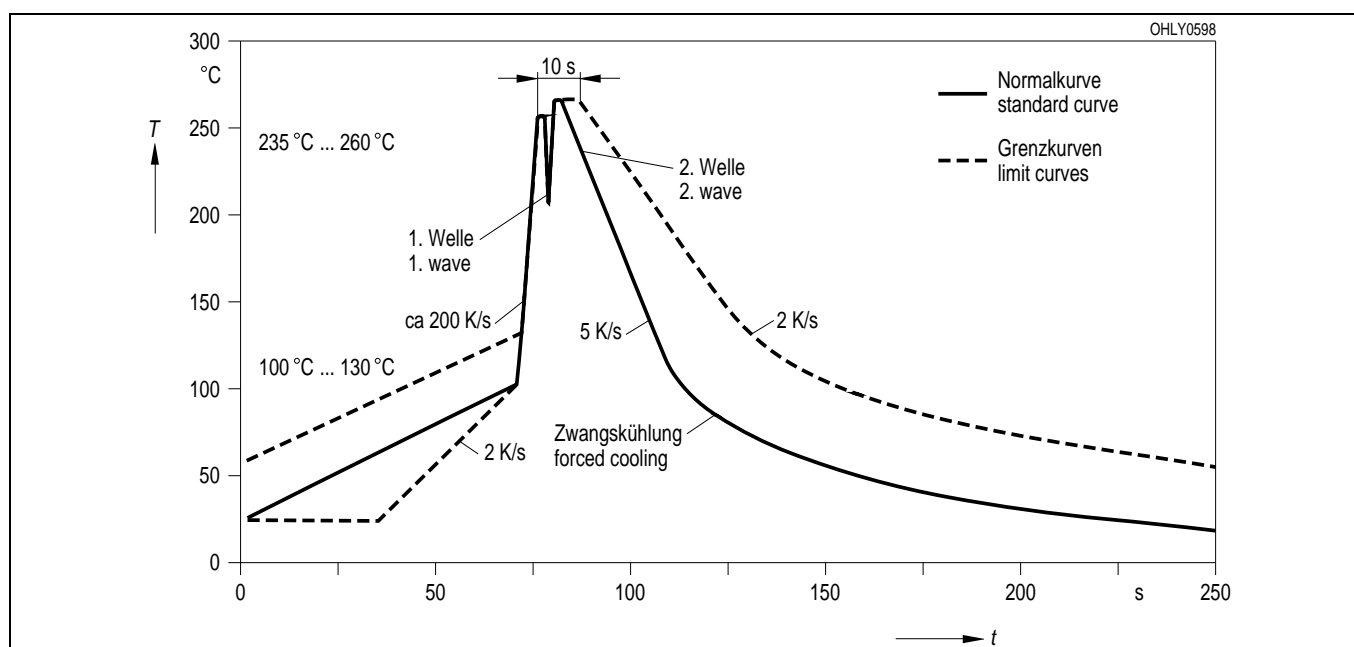

Barcode-Produkt-Etikett (BPL)
Barcode-Product-Label (BPL)

OSRAM Opto Semiconductors

Lxx xxxx Bin1: Bin Information Color 1
 Product Name Bin2: Bin Information Color 2
 Bin3:

(6P) BATCH NO: Batch Number
Bar Code

(1T) LOT NO: Lot Number (9D) D/C: Date Code
Bar Code

(X) PROD NO: Product Code (Q) QTY: Product Quantity per Reel (G) GROUP: X-X-X+X-X-X
 Color 1 Color 2
 Forward Voltage Group
 Wavelength Group
 Brightness Group

RoHS Compliant ML Temp ST
 2 245 C RT

Additional TEXT
 R077 DEMY
 PACKVAR: Packing Type

OHA22043

Gurtverpackung
Tape and Reel

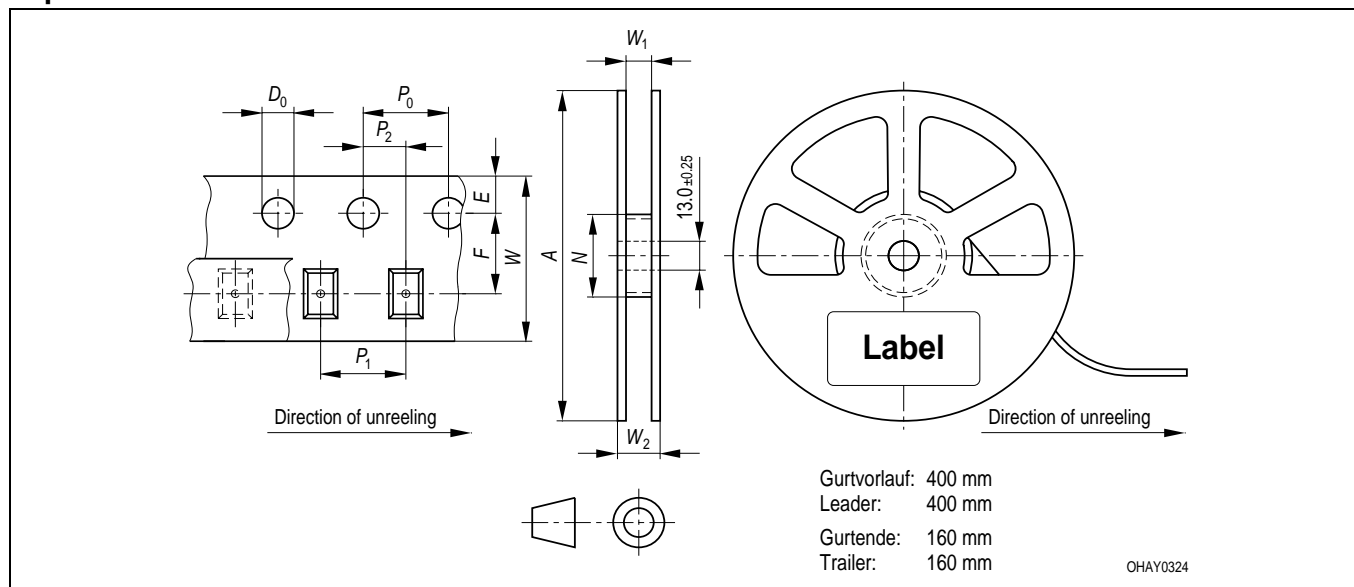

Tape dimensions in mm (inch)

W	P ₀	P ₁	P ₂	D ₀	E	F
8 + 0.3 - 0.1	4 ± 0.1 (0.157 ± 0.004)	4 ± 0.1 (0.157 ± 0.004)	2 ± 0.05 (0.079 ± 0.002)	1.5 + 0.1 (0.059 + 0.004)	1.75 ± 0.1 (0.069 ± 0.004)	3.5 ± 0.05 (0.138 ± 0.002)

Reel dimensions in mm (inch)

A	W	N _{min}	W ₁	W _{2 max}
180 (7)	8 (0.315)	60 (2.362)	8.4 + 2 (0.331 + 0.079)	14.4 (0.567)
330 (13)	8 (0.315)	60 (2.362)	8.4 + 2 (0.331 + 0.079)	14.4 (0.567)

Trockenverpackung und Materialien
Dry Packing Process and Materials

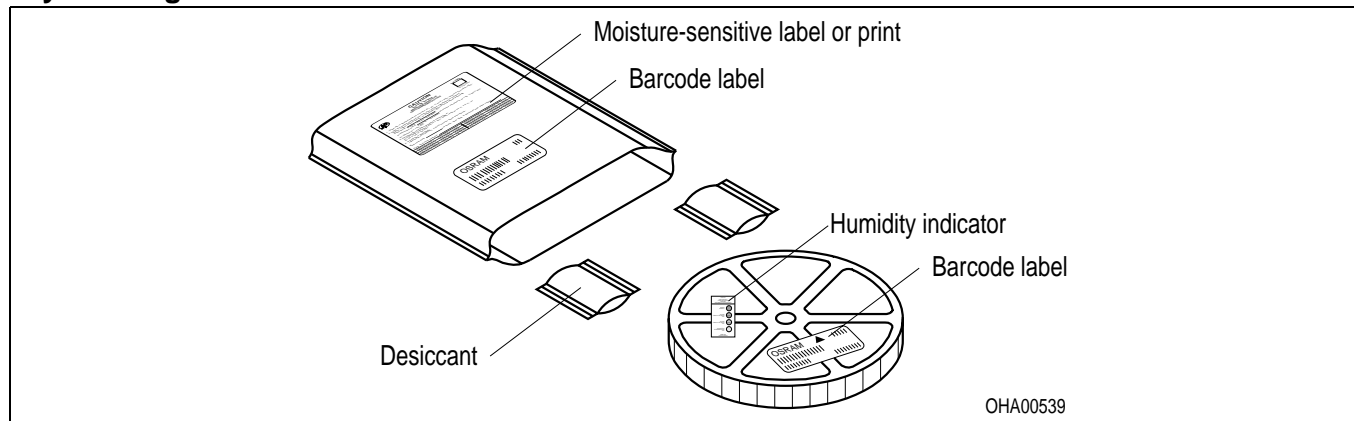

Anm.: Feuchteempfindliche Produkte sind verpackt in einem Trockenbeutel zusammen mit einem Trockenmittel und einer Feuchteindikatorkarte
 Bezüglich Trockenverpackung finden Sie weitere Hinweise im Internet und in unserem Short Form Catalog im Kapitel "Gurtung und Verpackung" unter dem Punkt "Trockenverpackung". Hier sind Normenbezüge, unter anderem ein Auszug der JEDEC-Norm, enthalten.

Note: Moisture-sensitive product is packed in a dry bag containing desiccant and a humidity card.
 Regarding dry pack you will find further information in the internet and in the Short Form Catalog in chapter "Tape and Reel" under the topic "Dry Pack". Here you will also find the normative references like JEDEC.

Kartonverpackung und Materialien
Transportation Packing and Materials

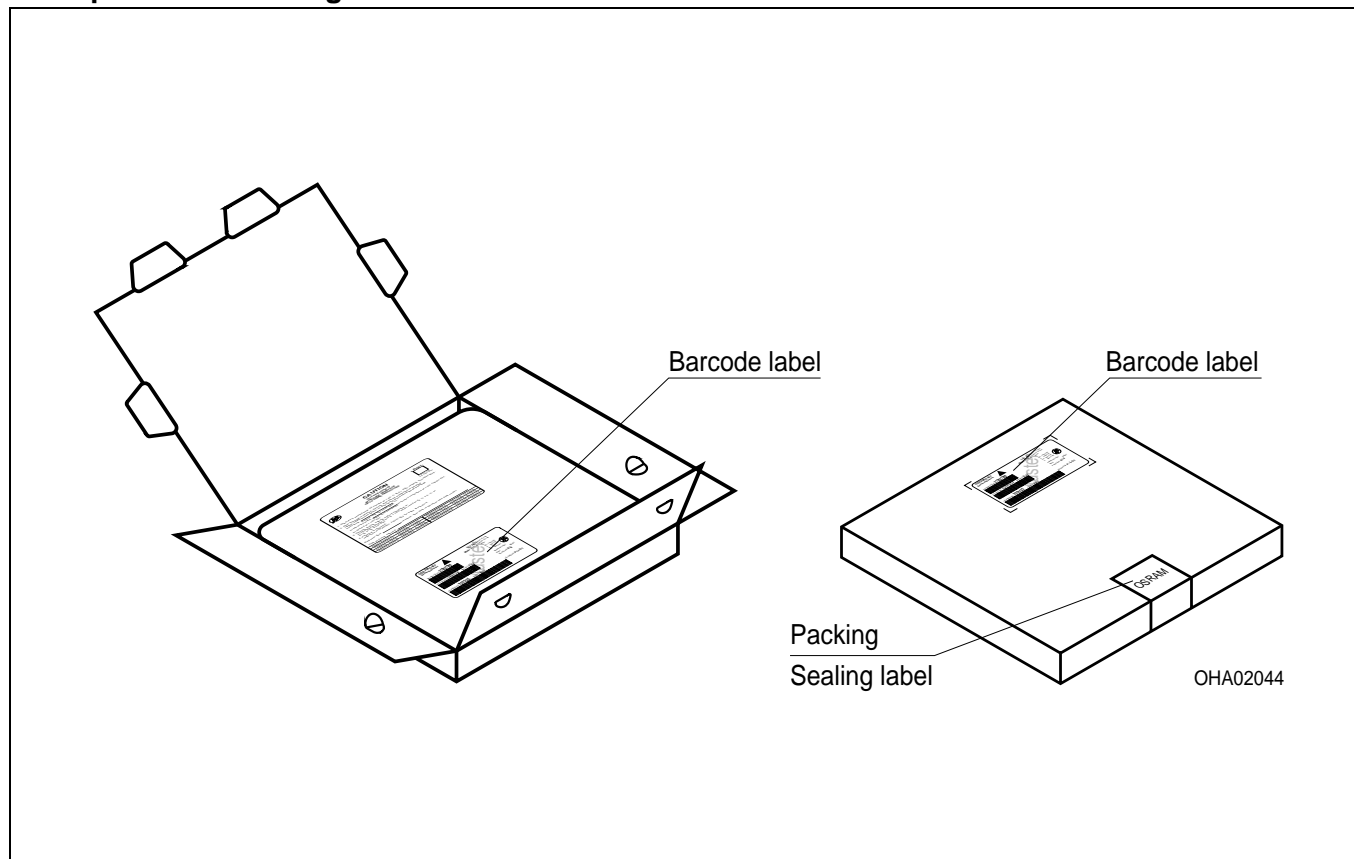

Revision History: 2010-03-02

Previous Version: 2007-03-01

Page	Subjects (major changes since last revision)	Date of change
2	new brightness grouping for super-red and green	2005-07-12
2	new ordering code	2005-07-27
7	Dimming Diagramm changed acc. to OS-IN-2006-028	2006-10-16
1, 9	additional information	2010-03-02

Attention please!

The information describes the type of component and shall not be considered as assured characteristics. Terms of delivery and rights to change design reserved. Due to technical requirements components may contain dangerous substances. For information on the types in question please contact our Sales Organization. If printed or downloaded, please find the latest version in the Internet.

Packing

Please use the recycling operators known to you. We can also help you – get in touch with your nearest sales office. By agreement we will take packing material back, if it is sorted. You must bear the costs of transport. For packing material that is returned to us unsorted or which we are not obliged to accept, we shall have to invoice you for any costs incurred.

Components used in life-support devices or systems must be expressly authorized for such purpose! Critical components^{9) page 16} may only be used in life-support devices or systems^{10) page 16} with the express written approval of OSRAM OS.